

SIDE ELEVATION "C"

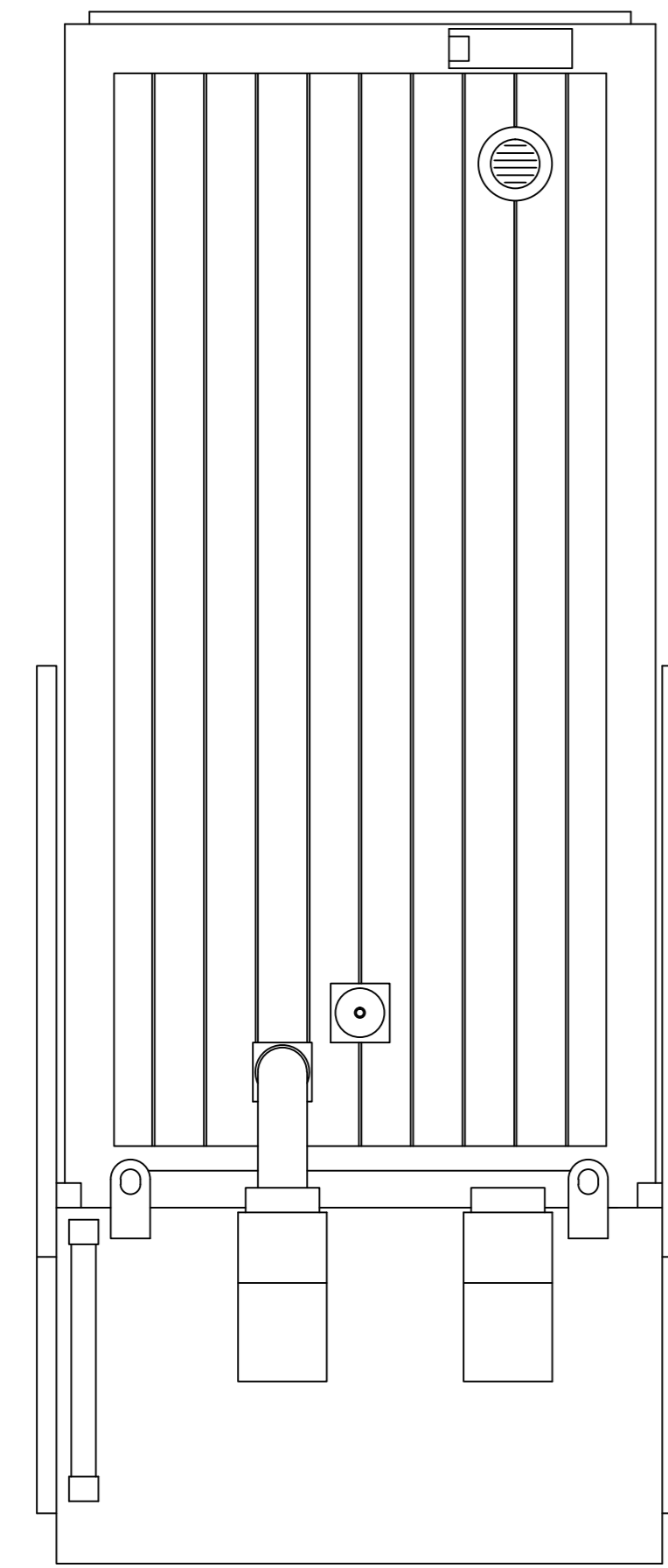

SECTIONAL PLAN

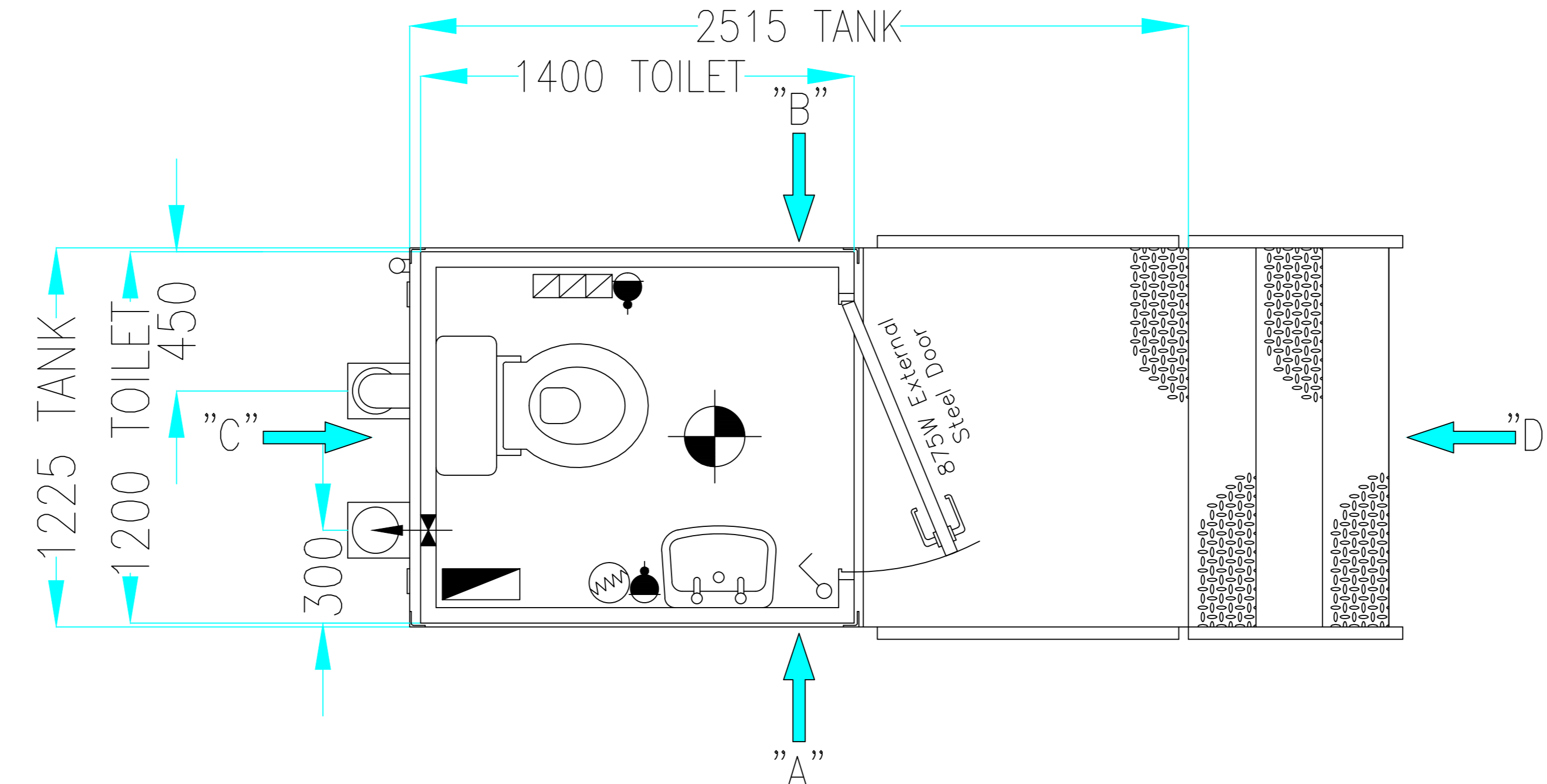

SIDE ELEVATION "D"

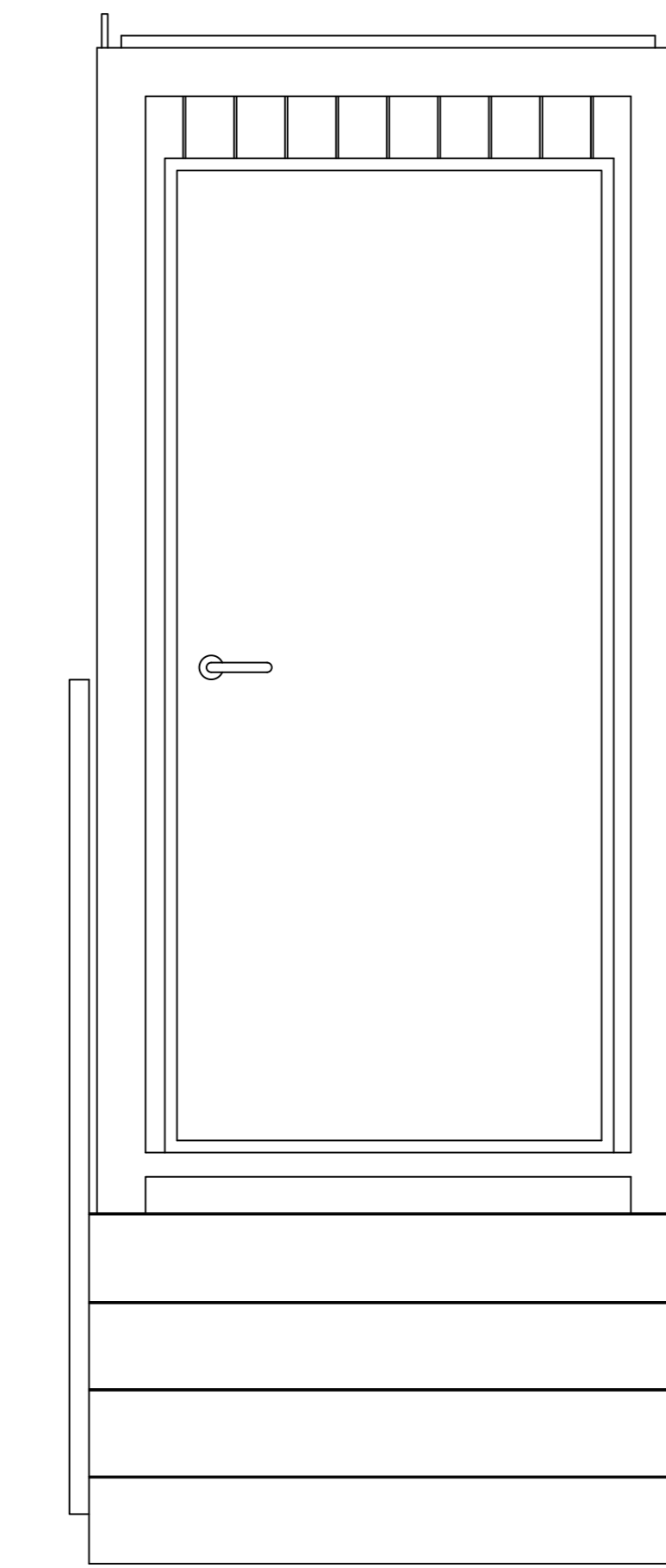

SIDE ELEVATION "A"

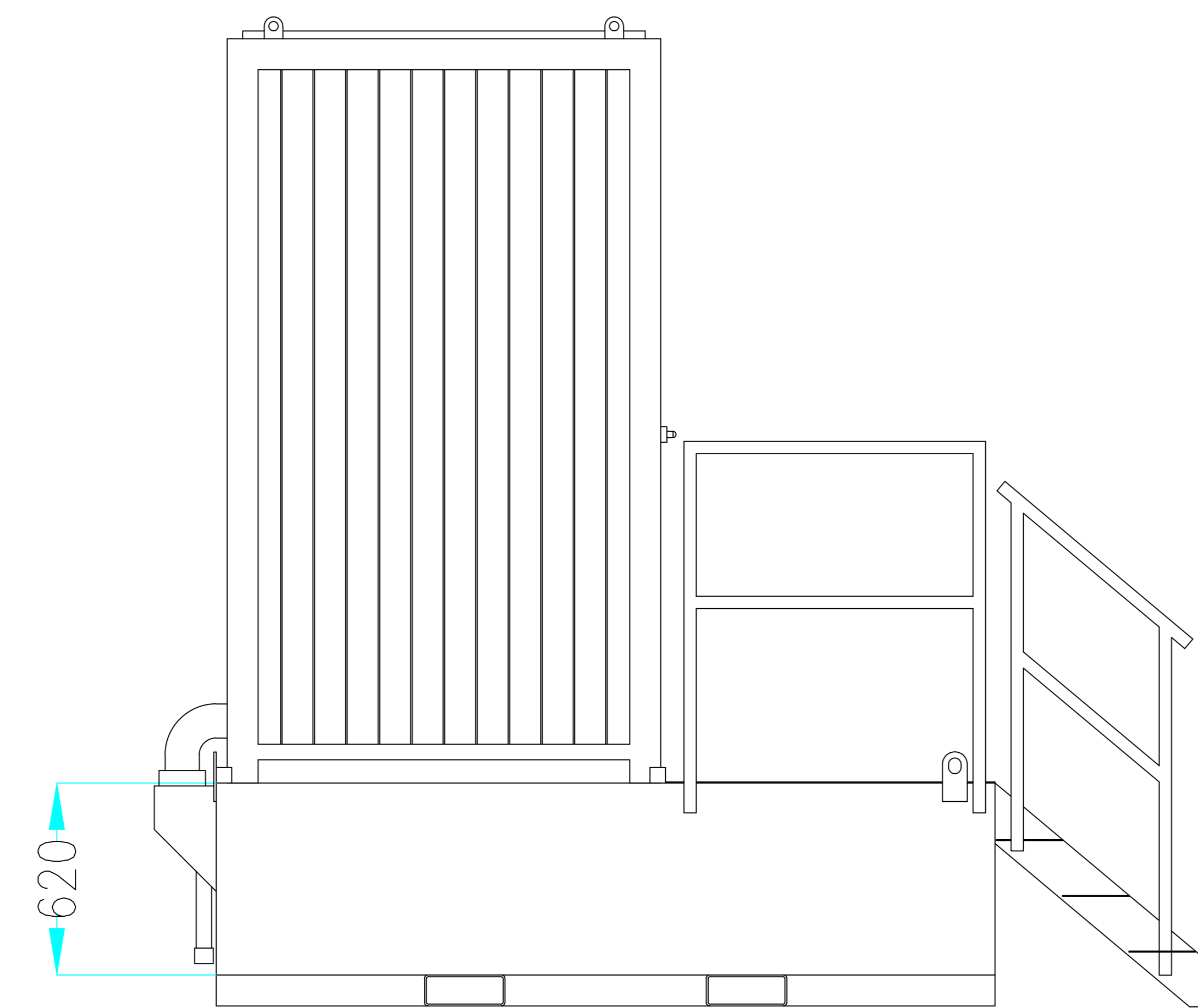

SIDE ELEVATION "B"

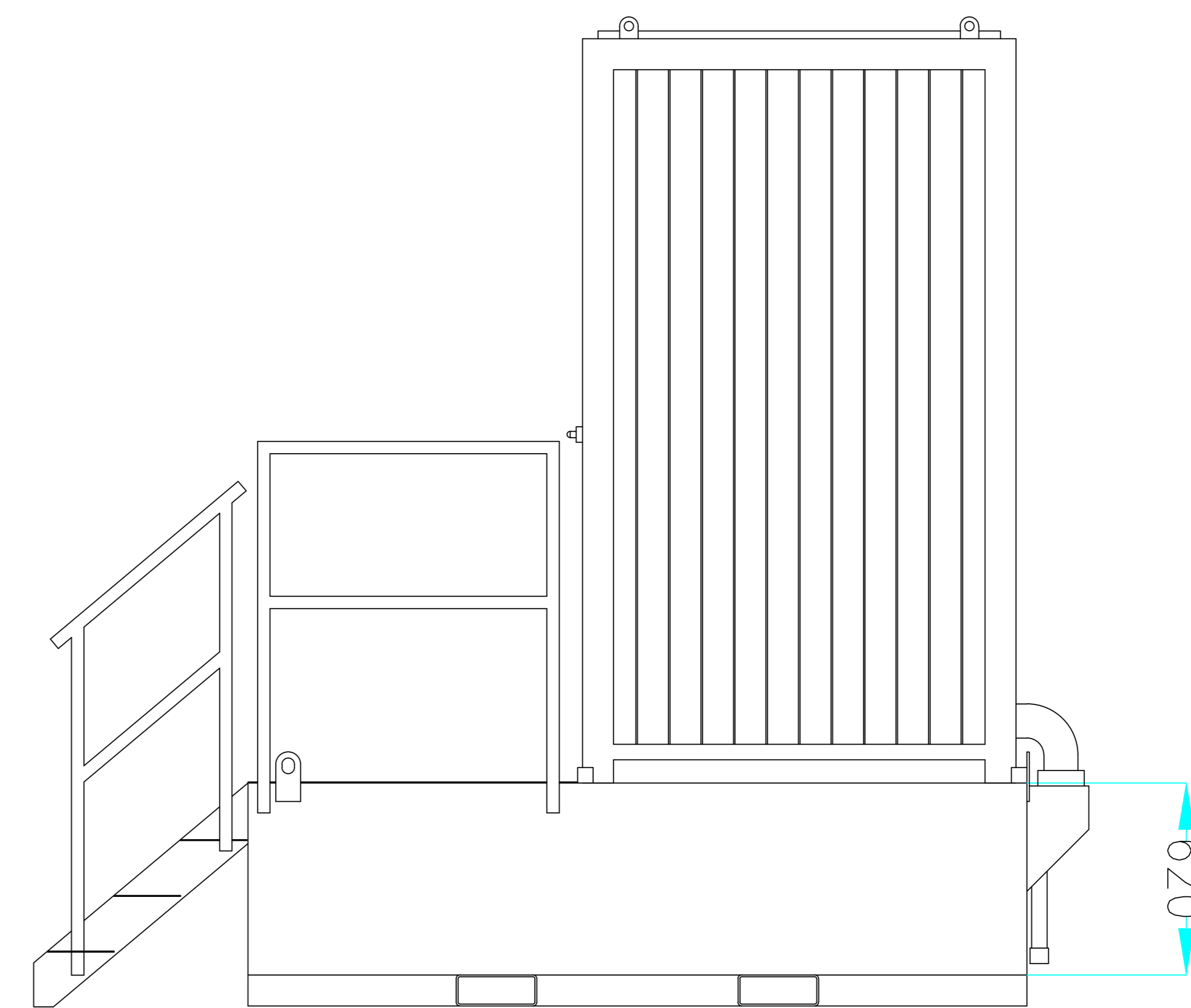

portablespace

cabin and container hire | sales | conversions

Unit 1, Red House Farm Business Units, Bacton, Suffolk, IP14 4LE

Tel: 01449 782123

Fax: 0845 3311434

Copyright in this drawing belongs to Portable Space Ltd. Neither the whole drawing nor any part thereof may be reproduced without the prior permission in writing of Portable Space Ltd

DRAWING STATUS

- 1 PRELIMINARY (FOR INFORMATION ONLY)
- 2 CLIENT APPROVED
- 3 ISSUED FOR MANUFACTURE
- 4 AS BUILT

COLOUR: RAL TBC

OVERALL CAPACITY (M3):	*
UNLADEN WEIGHT (KG)	*
MAXIMUM LADEN WEIGHT (KG)	*
MAXIMUM LIFT WEIGHT (KG)	*

- DISTRIBUTION BOARD
- CONVECTOR HEATER
- TUBULAR HEATER
- HIGH LEVEL FAN HEATER
- RED BULKHEAD 16W PLS
- 1500mm VAPOUR PROOF FLUORESCENT LIGHT
- BULKHEAD LIGHT
- WATER HEATER
- 13A TWIN SOCKET - LOW
- 13A TWIN SOCKET - HIGH

- SWITCH SPUR
- WALL LIGHT SWITCH
- PULL LIGHT SWITCH
- THERMOSTAT
- EXTRACTION FAN
- SHOWER HEATER
- FROST STAT
- VENT
- E.S 12mm EARTHING STUD

- OIL FILLED RADIATOR
- EMERGENCY EXIT LIGHT
- 3-POINT LOCKING
- PEDESTRAIN FIRE DOOR
- WINDOW (NO SHUTTER)

Additional Details:

Title

PORTABLE SPACE LTD:
SINGLE MAINS TOILET TANK

Unit Type

SINGLE MAINS TOILET TANK

Date	Scale	Drawn By
30-01-19	N.T.S	LG
Q No.	Drawing No.	Rev.
*	QC-651	0

Revision Details:

*